

# NEEDLE STRIPES FOR COMPOSITE LAYER MACHINES NEEDLE STRIPES INQUIRY

**RICHIESTA OFFERTA NEEDLE STRIPES**

**COMPANY NAME**

DITTA \_\_\_\_\_  
 NAME \_\_\_\_\_  
 E-MAIL \_\_\_\_\_  
 PHONE \_\_\_\_\_





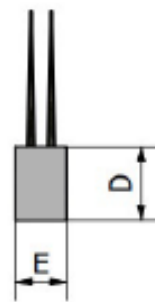
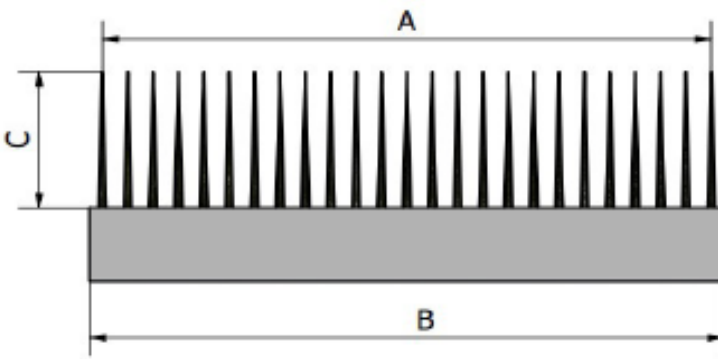

**REFERENCE**

RIFERIMENTO \_\_\_\_\_



- A= \_\_\_\_\_ mm (Standard 49 mm)
- B= \_\_\_\_\_ mm (Standard 50 mm)
- C= \_\_\_\_\_ mm (Standard 12.5 mm)
- D= \_\_\_\_\_ mm (Standard 6.5 mm)
- E= \_\_\_\_\_ mm (Standard 4 mm)

PINS DIAMETER 0.62 mm

	2 rows 2 file	3 rows 3 file	4 rows 4 file
normal			
staggering			
	density for row _____ cm (standard 10 pins/cm)	density for row _____ cm (standard 10 pins/cm)	density for row _____ cm (standard 10 pins/cm)

**EXEMPLE 1**

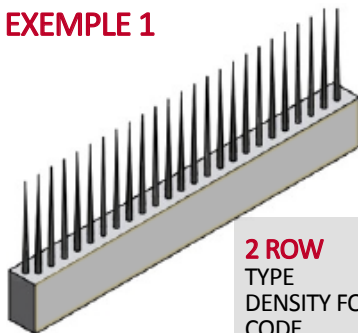

**2 ROW**  
 TYPE  
 DENSITY FOR ROW  
 CODE

Staggering  
 10 pins/cm  
**NSKM2102221**

**EXEMPLE 2**

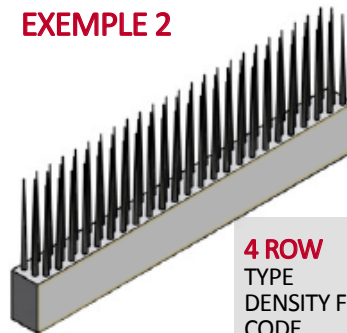

**4 ROW**  
 TYPE  
 DENSITY FOR ROW  
 CODE

Staggering  
 10 pins/cm  
**NSKM2102224**



# NEEDLE STRIPES FOR COMPOSITE LAYER MACHINES

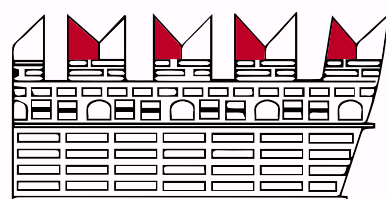
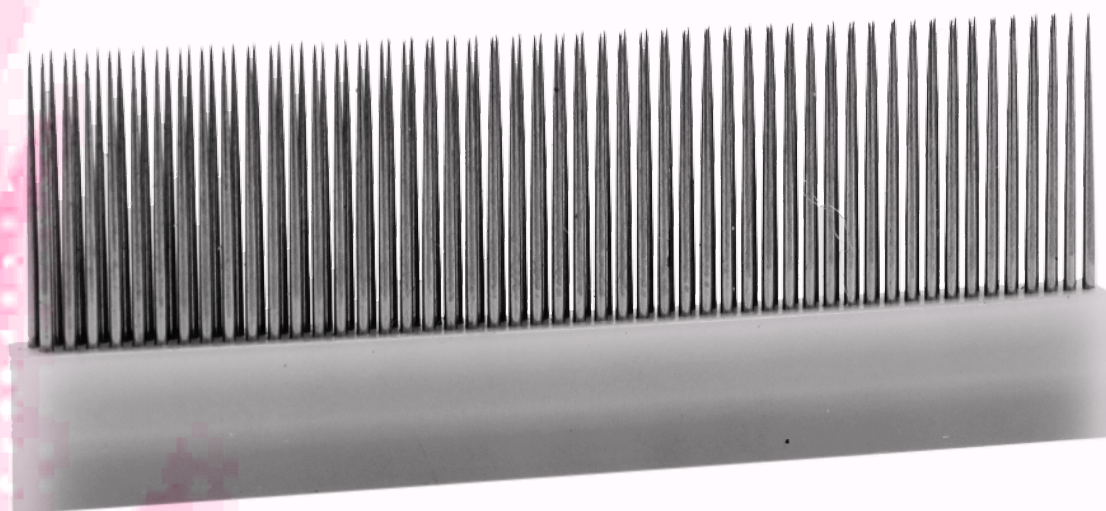
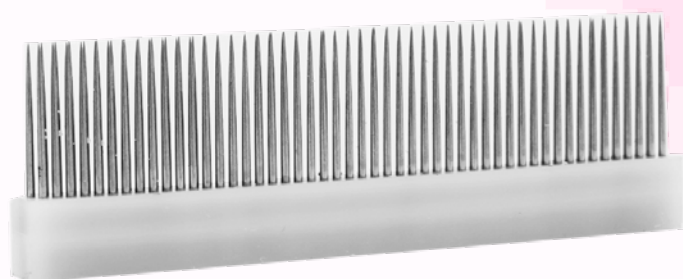
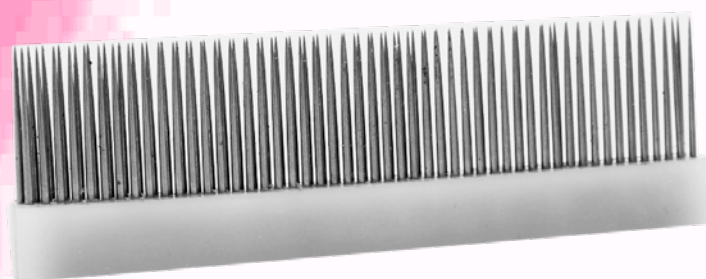

**CASTELLO**

OFFICINE dal 1948